

# Hands-On RFID: Wireless Wearables for Detecting Use of Objects

Kenneth P. Fishkin, Matthai Philipose, Adam Rea

*Intel Research Seattle*

*{kenneth.p.fishkin, matthai.philipose, adam.d.rea} @ intel.com*

## Abstract

*Recent research has explored ways to obtain and use knowledge of person-object interactions. We present a novel pair of wearables, a glove and a bracelet, that detect when users interact with unobtrusively tagged objects. The glove can also report whether the grasp was with the palm or the fingertips. Both devices have been built and deployed. We present the requirements, design and early experiences.*

## 1. Introduction

Knowing what physical objects a person touches is central to many applications. Logs of objects touched during the day can be the basis of “experience sampling” [1] or “capture” [4] programs that try to reconstruct a user’s day. The ability to designate a physical object of interest may form the basis of touch-based user interfaces, where the user performs explicit virtual actions (such as web queries) parameterized by physical objects [5, 10]. Perhaps most intriguingly, recent work [6, 7] has shown that, for a large variety of physical activities, the sequence of objects used serves as a strong indicator of the activity being performed. Activity-based applications such as health monitoring, factory-floor maintenance and context-sensitive reminders may thus benefit from awareness of objects used.

A practical system for enabling these applications needs to detect touches of many objects of many types, distinguish between instances of the same object type, and be accurate. The system should be unobtrusive: users should be able to function without being aware that the system is at work. It should support privacy: for instance, users should be able to “opt-out” of the system. Finally, it should allow inexpensive, incremental deployment and require little maintenance.

In this paper, we present a practical wearable system that satisfies most of these constraints. We focus on techniques for achieving design requirements and sketch our early experiences.

## 2. Related Work

Existing techniques for detecting object use can be divided into those that require modification of the object to be used, and those that do not. Computer vision [8] is by far the most popular example of the latter. Although vision has the potential for satisfying most of the design constraints in principle, practical systems have proved very difficult to engineer. Furthermore, video cameras, especially in non-public spaces, provoke strong privacy concerns.

Of techniques that modify objects, tagging objects with a remotely readable identification tag is the most common approach. “Active” tags [2], while extremely accurate, carry an on-board power supply and have the fundamental problem that their batteries need to be replaced eventually, making them unsuitable for tagging large numbers of low-value objects. “Passive” tags, which harvest incident energy to sense and communicate, are somewhat less accurate than active ones (in particular tags may not be read if reader and tag are poorly aligned). However, their low cost, small size and lack of battery are overwhelming advantages if the tagging is to scale to many objects over long periods.

A key challenge with passive tags is to make their use as unobtrusive as possible. The barcode [10] is the most ubiquitous passive tagging technology. However, it requires a direct line of sight between reader and tag, so that detecting a tagged object requires explicit scanning with a handheld device. Radio Frequency Identification (RFID) tags can return a unique identifier to a nearby scanning reader even without direct line of sight (or strict relative orientation requirements). Schmidt *et al.* [9] pioneered the idea of integrating an RFID reader into a glove so that tags on objects touched by the glove can be detected by the embedded reader. However, their system comprised a heavy glove, with wires for power and communications leading to a hip-mounted power unit/reader that was further connected to a “wearable computer” that processed the data. In what follows, we describe how miniature RFID reader, power supply and wireless unit can be integrated to transform even

lightweight accessories such as surgical gloves and bracelets into unobtrusive, autonomous object-touch detectors.

### 3. Design Schematic

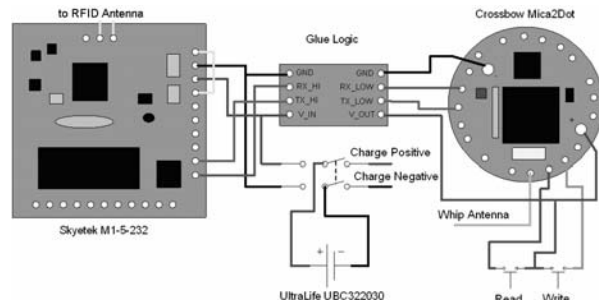

**Figure 1: Schematics for wearable RFID reader**

Our wearable reader has three components (Figure 1). For the RFID sensor, we used the Skyetek M1 13.56MHz reader. 13.56MHz tags are available off-the-shelf, are inexpensive, and have a small, postage-stamp size form factor. Using the M1 allows us to add only minimal “glue” logic (a voltage regulator and an additional level converter) to interface this board with the rest of our reader system. The M1 interfaces to an RFID antenna, to be matched to the M1’s 50Ω impedance.

To report sensed events, we chose to use a Crossbow Mica2Dot mote radio, which reported sensed events wirelessly to a PC base station which may be 15 to 30m away. We wirelessly offload the data, despite its energy cost, both to support real-time analysis based on the data stream, and to keep the device small and autonomous. We chose a mote instead of Bluetooth due to its drastically lower connection latency and power requirements, as well as the embedded controller’s ability to control the RFID board. To conserve power, we programmed the mote to power down the RFID board when not actively polling.

For the power source, we used a rechargeable Lithium Polymer (Li-Poly) battery and developed a USB charging system to make the overall system as portable and convenient to use as possible.

All the components, except the RFID antenna are quite small: the M1 board (3.8 x 3.8 x 0.8 cm) is the bulkiest. The pieces can therefore fit into large watch-dial. The RFID antenna needs to be 7-12cm across, and is typically designed to span the palm or wrist of the user. Net RF energy levels are well under FCC/OSHA limits.

### 4. The iGlove



**Figure 2: The iGlove: Bike (l) & medical (r) gloves**

The modified bike glove to the left of Figure 2 was our first prototype. All components except the RFID antenna are housed in the box on the glove. The iGlove samples twice a second; any tag ID seen is broadcast over the mote radio. For the RFID antenna, we built a simple copper tape single turn loop antenna. We individually tuned and matched each glove antenna to match the 50Ω impedance of the M1 front end. While this prototype was too crude for a true deployment, it was usable and durable enough that we were able to have 14 volunteers wear it and conduct a variety of daily household tasks, averaging around 45 minutes per user. By matching the objects the users grasped to statistical models, we could infer which activities they performed with 70-90% accuracy [7].

Our next deployment was aimed at tracking equipment usage by first year medical students at the University of Washington Medical School. Students in training use a simulator, routinely wear surgical gloves, and interact with a number of objects as they use the simulator (right of Figure 2). To extend the iGlove to this more challenging environment required some design advances.

The tools used were often grasped with the fingers and therefore out of range of the palm antenna. An antenna in the fingertip was most effective in countering the range problem. A complication is that fingertip antennae should not reduce fingertip sensitivity. Working with the Paralec Corporation, we therefore created silver ink printed antennae on a Kapton polyimide flexible substrate. While the detection range of these finger tip antennae was only a few centimeters, it was sufficient, and users reported that it didn’t interfere with their workplace motions or comfort.

While the students were willing to wear gloves, they must fit unobtrusively under their existing latex gloves. Accordingly, we took most of the circuitry off the hand and moved it to a wrist “cuff”, connected to

the palm antennae by thin wires. Because we were trying not to interfere with the normal movements of the students, significant care was taken to design the enclosure and circuitry such that the unit had a minimal profile and negligible weight.

In our test deployment, we had 7 volunteers from the medical school faculty perform a simulation wearing these gloves, averaging roughly 30 minutes per volunteer. All reported that the form factor was acceptable, and we were able to get an object-use trace sufficient for tracking the medical procedures [3]. However, an unexpected problem was that the stress exerted by the doctors' fingers, along with sweat, pulled wired out of their connectors (although these were carefully attached for robustness) and rubbed away printed conductive ink, resulting eventually in device failure. In fact, the constant, heavy usage of various surfaces of the hand makes a durable glove-based solution difficult to engineer.

## 5. The iBracelet

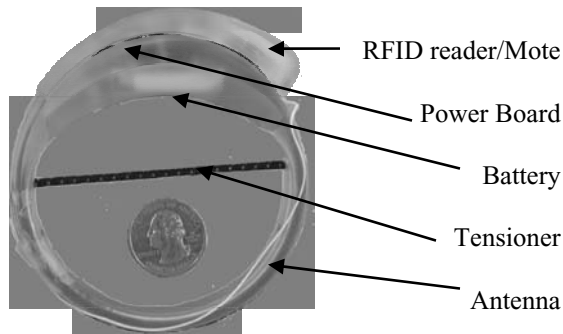

Figure 3: The iBracelet

Although the iGlove is appropriate for domains where users typically wear gloves (such as machine maintenance and medical care), it is far too cumbersome for domains such as in-home eldercare. Engineering wires, connectors and antennas that survive the stress and sweat on hand surfaces is challenging. We therefore created a bracelet, called the iBracelet, targeted at detecting tags on grasped objects.

Placing the antenna on the wrist (as opposed to the palm) distances it from tags on objects by 10cm (as opposed to 2-5cm) or so. The antenna is now also partially blocked by the wrist, leading to concerns that it may be detuned. We using a tuned multi-turn printed circuit board (PCB) circular loop antenna, mounted perpendicularly to the axis of the arm, to address these challenges. The multiple turns of the antenna increased the gain of the antenna in the plane of interest, increasing the range precisely where it was most

desirable. By changing the antenna substrate to PCB, we were able to stack the turns of the antennas in layers of the board (reducing the width of the antenna) as well as leveraging a much more precise, durable and repeatable set of construction parameters. Also, because the actual antenna copper was quasi encapsulated in the PCB and mask (unlike the exposed copper ink in polyimide antennae) the effects of stray capacitive coupling were almost completely eliminated, improving the overall efficiency of our design.

For durability, the antenna would have to be encased in a durable housing, yet the housing could not interfere with the antenna performance. We found that an epoxy resin over-molding gave us a surprisingly rigid, durable housing while having little impact on antenna performance. To fit the curvature of the arm, the components had to be un-stacked and angled, so that the weight of the unit could be distributed across the whole outer edge of the prototype, while minimizing the height of the unit as well. The entire bracelet weighs roughly 60 grams.

While performance varies depending on the individual user, the size of the antenna, and the antenna tuning, we ran a simple test to demonstrate typical performance. A 13.56MHz tag was placed at a varying distance from the bracelet, while the bracelet was being worn. This was done 20 times at each distance, with a distance increment of 0.5 cm. The graph in Figure 4 shows the results: we can see that the bracelet exhibits perfect detection up to 10cm, and then drops off rapidly, with no detection after 11cm.

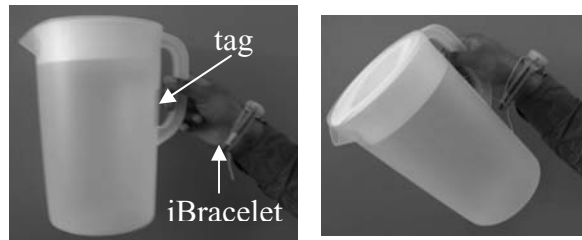
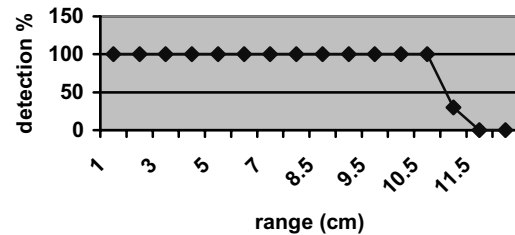

Figure 4: iBracelet usage. Tag detection falloff with range (top). Unfavorable (left) and favorable (right) relative positions for tag and reader.

## 6. Dealing with Inaccuracy

When used for detecting intentional touches of objects, hand-worn RFID readers can return both false negatives (a missed touch of an object) and false positives (accidental touches of an object). Both errors are common enough that any system that uses the output of these readers should be robust to both. An activity inferencing system that, when the user brushes their hand by a salt shaker on the way to grasp a coffee cup, concludes that they have put salt in their coffee, will be of limited utility.

For many applications, standard statistical approaches to modeling sensor data may serve quite well to counter both kinds of errors. In the SHARP system [7] for inferring human activities, for instance, we model activities as left-right Hidden Markov Models where the observations are object touches. Intuitively, the models specify the sequence of steps for each activity and the probability of touching individual objects in each step. The latter probabilities are set up so that, in each step, there is at least a miniscule probability of using, or not using, any object i.e. object-use probabilities are never 0 or 1. In the absence of correlated errors in observations of objects, therefore, both missed sightings of essential objects and accidental sightings of irrelevant objects are accounted for by the models.

In other cases, however, there is no alternative to substantially improving the accuracy of the reader. An application may be monitoring a checklist of critical objects to be used, for instance, and each missing reading may result in user notifications. The challenge here is that false negatives mostly result from inadequate reader range: the grasping surface of an object may well be more than 10cm away from its tag, as the lower half of Figure 4 shows. Unfortunately, increasing the range substantially also increases the possibility that tagged objects that happen to be near the reader are detected as being used i.e., reducing false negatives increases false positives. In fact, our recent results indicate that it should be possible to increase reader range to 30cm or so. However, tuning the range to achieve an acceptable precision/recall tradeoff seems destined to be an application-specific issue.

## 7. Conclusions

RFID-based object touch sensors have the potential to provide computers with a view of human activity that is unprecedented in its detail and breadth. Recent advances in miniaturization of system components have yielded wearables that are can track object use both unobtrusively and effectively. Challenges remain,

however, in improving the ruggedness and accuracy of these devices.

## Acknowledgments

We thank Waylon Brunette for his mote programming, Ken Smith for helping design the iBracelet enclosure and Gretchen Cox for sewing the iGloves.

## References

1. Barrett, L.F., Barrett, D.J., "An Introduction to Computerized Experience Sampling in Psychology". *Social Science Computer Review*. Vol. 19, No. 2, Summer 2001, pp. 175-185.
2. K. Finkenzerler, *RFID Handbook*, 2nd ed., John Wiley & Sons, 2003.
3. K. Fishkin, S. Consolvo, J. Rode, B. Ross, I. Smith, and K. Souter. "Ubiquitous Computing Support for Skills Assessment in Medical School" UbiHealth 2004 Workshop.
4. Hayes, G.R., Kientz, J.A., Truong, K.N., White, D.R., Abowd, G.D., Pering, T. "Designing Capture Applications to Support the Education of Children with Autism," *UbiComp 2004*, pp. 161-178.
5. Ishii, H. and Ulmer, B. "Tangible Bits: Towards Seamless Interfaces between People, Bits, and Atoms". *Proceedings of CHI'97*, pp. 234-241.
6. E. Munguia Tapia, S. S. Intille, and K. Larson, "Activity recognition in the home setting using simple and ubiquitous sensors," in *Proceedings of Pervasive 2004*, vol. LNCS 3001, pp. 158-175.
7. M. Philipose, K. Fishkin, M. Perkowitz, D. Patterson, D. Fox, H. Kautz and D. Hähnel. "Inferring Activities from Interactions with Objects". *IEEE Pervasive Computing*, October 2004, pp. 50-57
8. B. C. S. Sanders, R. C. Nelson, and R. Sukthankar, "The OD Theory of TOD: The use and limits of temporal information for Object Discovery," In *Proc. AAAI*, 2002.
9. A. Schmidt, H-W. Gellersen and C. Merz. "Enabling Implicit Human Computer Interaction - A Wearable RFID-Tag Reader". *ISWC2000*, pp193-194.
10. Smith, Marc, Duncan Davenport, Howard Hwa. "AURA: A mobile platform for object and location annotation", *UbiComp 2003*.